

Please check the examination details below before entering your candidate information

Candidate surname					Other names				
Centre Number					Candidate Number				
<input type="text"/>	<input type="text"/>	<input type="text"/>	<input type="text"/>	<input type="text"/>	<input type="text"/>	<input type="text"/>	<input type="text"/>	<input type="text"/>	<input type="text"/>

**Pearson Edexcel International Advanced Level**

**Friday 10 January 2025**

Afternoon (Time: 1 hour 45 minutes) **Paper reference** **WPH14/01**

**Physics**

**International Advanced Level**

**UNIT 4: Further Mechanics, Fields and Particles**

<b>You must have:</b> Scientific calculator, ruler	Total Marks
---	-------------

### Instructions

- Use **black** ink or ball-point pen.
- If pencil is used for diagrams/sketches/graphs it must be dark (HB or B).
- **Fill in the boxes** at the top of this page with your name, centre number and candidate number.
- Answer **all** questions.
- Answer the questions in the spaces provided  
– *there may be more space than you need.*
- **Show all your working out** in calculations and **include units** where appropriate.

### Information

- The total mark for this paper is 90.
- The marks for **each** question are shown in brackets  
– *use this as a guide as to how much time to spend on each question.*
- In the question marked with an **asterisk (\*)**, marks will be awarded for your ability to structure your answer logically, showing how the points that you make are related or follow on from each other where appropriate.
- The list of data, formulae and relationships is printed at the end of this booklet.

### Advice

- Read each question carefully before you start to answer it.
- Try to answer every question.
- Check your answers if you have time at the end.

Turn over ►

P78478A

©2025 Pearson Education Ltd.  
H:1/1/1/1/1/



  
Pearson

## SECTION A

Answer ALL questions.

For questions 1–10, in Section A, select one answer from A to D and put a cross in the box .  
If you change your mind, put a line through the box  and then  
mark your new answer with a cross .

- 1 Two sources produce waves with a phase difference of  $40^\circ$ .

Which of the following gives the angle of  $40^\circ$  in radians?

- A  $\frac{40 \times 2}{360}$
- B  $\frac{360}{40 \times 2\pi}$
- C  $\frac{40 \times}{360}$
- D  $\frac{360}{40 \times}$

(Total for Question 1 = 1 mark)

- 2 The standard quark-lepton model includes particles called mesons.

Which of the following is a meson?

- A photon
- B pion
- C positron
- D proton

(Total for Question 2 = 1 mark)



- 3 Two identical charged particles were placed in a vacuum 0.020 m apart. The charge on each particle was  $+8.0 \times 10^{-6}$  C.

Which of the following gives the magnitude of the force, in newtons, on each particle?

- A  $\frac{8.99 \times 10^9 \times (8.0 \times 10^{-6})}{0.020}$
- B  $\frac{8.99 \times 10^9 \times (8.0 \times 10^{-6})^2}{0.020^2}$
- C  $\frac{8.99 \times 10^9 \times (8.0 \times 10^{-6})^2}{0.020}$
- D  $\frac{8.99 \times 10^9 \times (8.0 \times 10^{-6})}{0.020^2}$

(Total for Question 3 = 1 mark)

- 4 The positron is the antiparticle of the electron.

Which row of the table gives a similarity and a difference between a positron and an electron?

	Similarity	Difference
<input type="checkbox"/> A	same lepton number	different baryon number
<input type="checkbox"/> B	same lepton number	different charge
<input type="checkbox"/> C	same mass	different baryon number
<input type="checkbox"/> D	same mass	different lepton number

(Total for Question 4 = 1 mark)

- 5 In alpha particle scattering experiments, alpha particles were directed at very thin gold foil.

Some alpha particles were deflected through angles up to  $180^\circ$ .

Which of the following could explain this observation?

- A Strong electrostatic forces act on the alpha particles.
- B The atom is mainly empty space.
- C The charge is evenly distributed in the atom.
- D The gold foil was very thin.

(Total for Question 5 = 1 mark)

DO NOT WRITE IN THIS AREA

DO NOT WRITE IN THIS AREA

DO NOT WRITE IN THIS AREA



P 7 8 4 7 8 A 0 3 3 2

- 6 Two coils, P and Q, are close to each other. An alternating supply is connected across coil P, as shown.

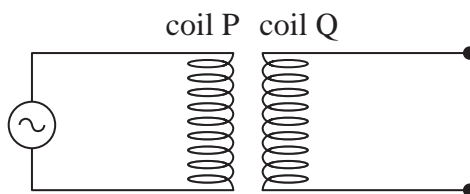

The number of turns on coil Q and the separation of coil P and coil Q can be changed.

Which row of the table gives the arrangement that produces the largest e.m.f. in coil Q?

	Number of turns	Separation of P and Q
<input type="checkbox"/> A	fewer turns in coil Q	closer together
<input type="checkbox"/> B	fewer turns in coil Q	further apart
<input type="checkbox"/> C	more turns in coil Q	closer together
<input type="checkbox"/> D	more turns in coil Q	further apart

(Total for Question 6 = 1 mark)

- 7 In pair production, a high energy photon creates a particle-antiparticle pair.

In one interaction, a photon produces an electron and a positron.

Which of the following gives the photon energy, in joules?

- A  $9.11 \times 10^{-31} \times (3 \times 10^8)^2$
- B  $1.67 \times 10^{-27} \times (3 \times 10^8)^2$
- C  $2 \times 1.67 \times 10^{-27} \times (3 \times 10^8)^2$
- D  $2 \times 9.11 \times 10^{-31} \times (3 \times 10^8)^2$

(Total for Question 7 = 1 mark)



8 The diagram shows a particle track in a bubble chamber.

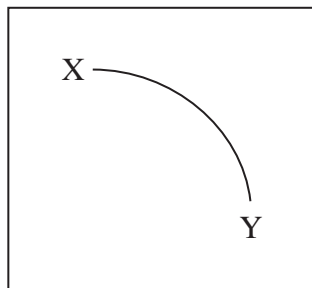

Which of the following is a valid conclusion from this track?

- A The particle is negatively charged.
- B The particle is moving from X to Y.
- C The speed of the particle is increasing.
- D The particle experiences a centripetal force.

(Total for Question 8 = 1 mark)

9 The graph shows how electric field strength varies with distance from a charged conducting sphere.

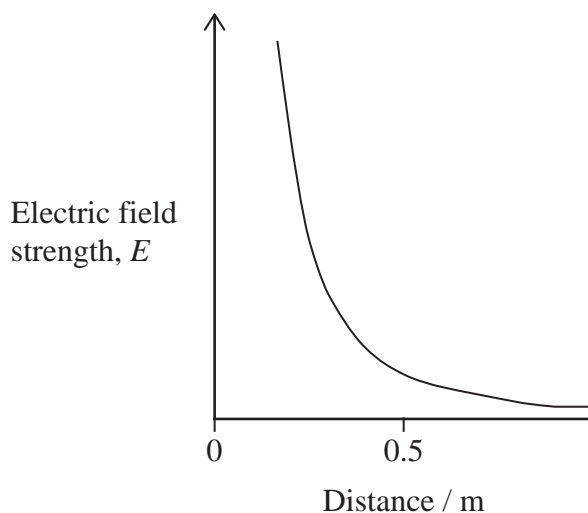

Which of the following gives the electric potential at a distance of 0.5 m from the sphere?

- A The area under the graph from 0 to 0.5 m.
- B The area under the graph from 0.5 m to infinity.
- C The gradient of the tangent to the graph at 0.5 m.
- D The value of  $E$  at 0.5 m divided by 0.5 m.

(Total for Question 9 = 1 mark)

DO NOT WRITE IN THIS AREA

DO NOT WRITE IN THIS AREA

DO NOT WRITE IN THIS AREA



10 A charged capacitor  $C_1$  stores energy  $W_1$ . A charged capacitor  $C_2$  stores energy  $W_2$ .

$C_1$  has half the capacitance of  $C_2$ .

$C_1$  is charged to half the potential difference of  $C_2$ .

Which of the following shows the ratio  $\frac{W_1}{W_2}$  ?

A  $\frac{1}{8}$

B  $\frac{1}{4}$

C 4

D 8

(Total for Question 10 = 1 mark)

**TOTAL FOR SECTION A = 10 MARKS**

DO NOT WRITE IN THIS AREA

DO NOT WRITE IN THIS AREA

DO NOT WRITE IN THIS AREA





- 12 The diagram shows a Van de Graaff generator. This is a device that produces a large potential difference by charging a conducting sphere.

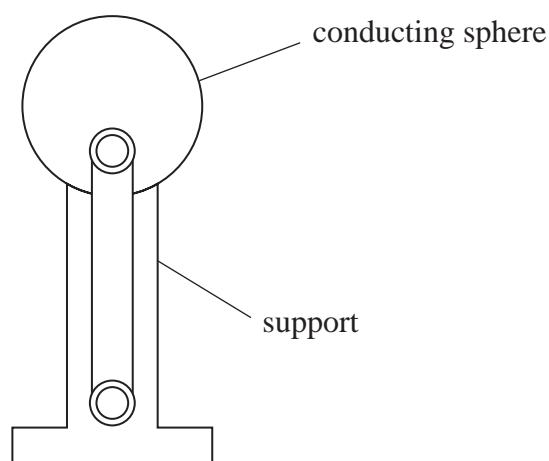

DO NOT WRITE IN THIS AREA

DO NOT WRITE IN THIS AREA

DO NOT WRITE IN THIS AREA

The conducting sphere of a Van de Graaff generator has a radius of 22.5 cm.

- (a) The electric potential produced at the surface of the conducting sphere is  $1.75 \times 10^4 \text{ V}$ .

Show that the charge on the sphere is about  $4.4 \times 10^{-7} \text{ C}$ .

(2)

.....

.....

.....

.....

- (b) Neon bulbs light when placed in a region of strong electric field.

A neon bulb is moved towards the charged sphere of the Van de Graaff generator. The neon bulb lights when the distance between the neon bulb and the centre of the charged sphere is 32.5 cm.

Determine the electric field strength at this position of the neon bulb.

(2)

.....

.....

.....

.....

Electric field strength = .....

(Total for Question 12 = 4 marks)



13 A power cable is supported by two pylons, as shown.

The length of the cable is 90 m. The current in the cable is 700 A.

Near the pylons, the Earth's magnetic field has a magnetic flux density of  $48 \mu\text{T}$  at an angle of  $20^\circ$  to the vertical.

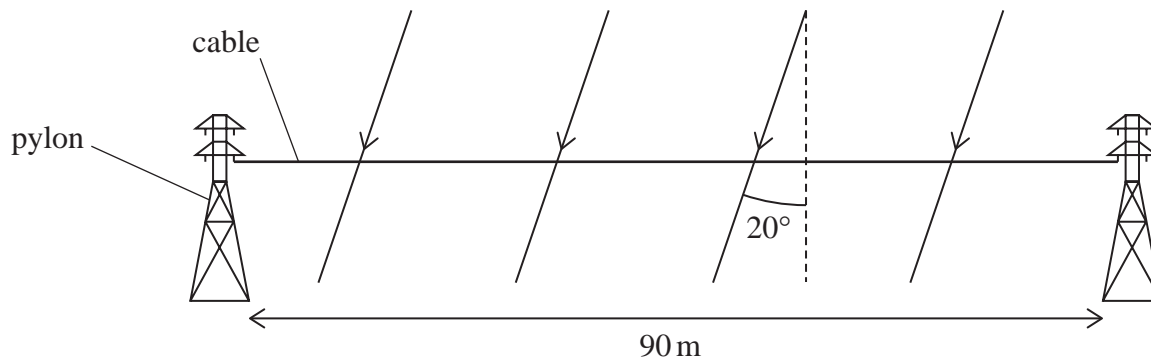

Determine the force on the cable due to the Earth's magnetic field.

Force = .....

(Total for Question 13 = 3 marks)



14 A cathode ray tube can be used to demonstrate the properties of electrons. In the cathode ray tube, a beam of electrons is produced using the arrangement shown.

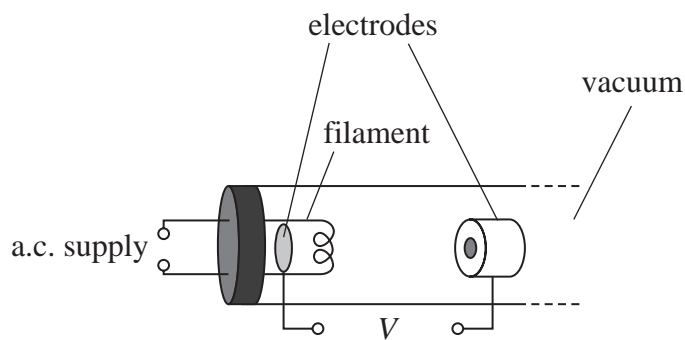

(a) Explain why electrons are released when there is a current in the filament.

(2)

.....

.....

.....

.....

.....

(b) In one cathode ray tube, the electrons in the beam had a de Broglie wavelength of  $2.65 \times 10^{-11}$  m.

Calculate the potential difference  $V$  required to accelerate these electrons between the electrodes.

(4)

.....

.....

.....

.....

.....

.....

.....

.....

.....

.....

$V =$  .....

(Total for Question 14 = 6 marks)

DO NOT WRITE IN THIS AREA

DO NOT WRITE IN THIS AREA

DO NOT WRITE IN THIS AREA



DO NOT WRITE IN THIS AREA

DO NOT WRITE IN THIS AREA

DO NOT WRITE IN THIS AREA

**BLANK PAGE**



15 A washing machine uses a rotating drum to wash clothes.

The photograph shows the drum inside a washing machine. The clothes are put in the drum.



(Source: © Tsetso Photo/Shutterstock)

The drum is a hollow metal cylinder with a series of holes through its surface.

At the end of the washing process the drum rotates at high speed.

(a) The drum of the washing machine rotates at 1400 revolutions per minute.

(i) Show that the angular velocity of the drum is about  $150 \text{ rad s}^{-1}$ .

(2)

.....

.....

.....

.....

(ii) The diameter of the drum is 45 cm.

Calculate the centripetal acceleration of a point on the circumference of the drum.

(2)

.....

.....

.....

Centripetal acceleration = .....



- (b) As the drum rotates at a high speed, clothes move in a vertical circle resting against the side of the drum.

The dot in the diagrams represents an item of clothing as it rotates with the drum.

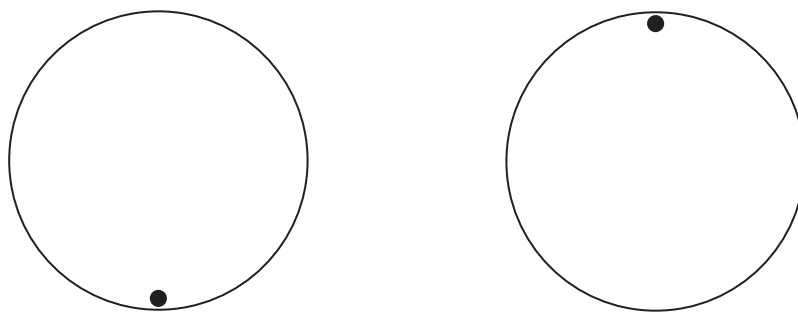

- (i) Add labelled arrows to each diagram to show the forces acting on the item of clothing.

(2)

- (ii) The drum rotates at constant speed.

Explain how the forces on the item of clothing vary between the bottom and the top of the drum.

(3)

.....

.....

.....

.....

.....

.....

.....

.....

.....



(iii) Water leaves the drum through the holes as the drum rotates.

Describe the path of the water as it leaves the holes.

(1)

(Total for Question 15 = 10 marks)

DO NOT WRITE IN THIS AREA

DO NOT WRITE IN THIS AREA

DO NOT WRITE IN THIS AREA



DO NOT WRITE IN THIS AREA

DO NOT WRITE IN THIS AREA

DO NOT WRITE IN THIS AREA

**BLANK PAGE**



16 In the early 20th century, Millikan carried out an experiment to determine the magnitude of  $e$ , the electronic charge. Charged oil droplets were introduced into a region of electric field produced between two parallel plates.

A potential difference was connected across the two plates.

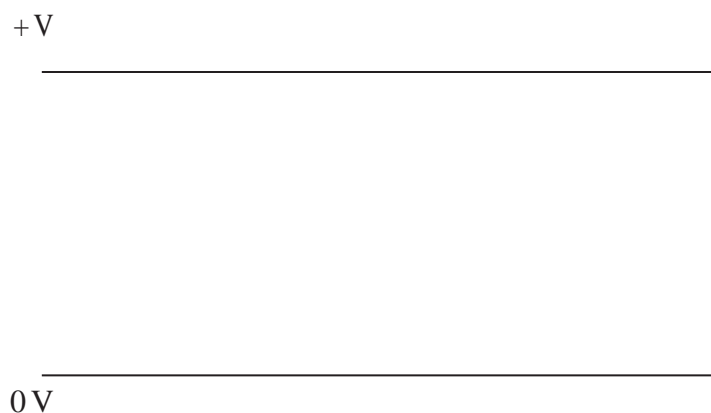

(a) Add to the diagram to show the field lines between the plates.

(2)

DO NOT WRITE IN THIS AREA

DO NOT WRITE IN THIS AREA

DO NOT WRITE IN THIS AREA



- (b) A charged oil drop entered the region of electric field between the plates. The plates were 1.5 cm apart. A potential difference of 85 V was applied between the plates and the charged oil drop was brought to rest.

Deduce whether the charge on the oil drop was a whole number multiple of the electronic charge.

$$\text{volume of oil drop} = 5.0 \times 10^{-19} \text{ m}^3$$

$$\text{density of oil} = 920 \text{ kg m}^{-3}$$

(5)

(Total for Question 16 = 7 marks)

DO NOT WRITE IN THIS AREA

DO NOT WRITE IN THIS AREA

DO NOT WRITE IN THIS AREA



P 7 8 4 7 8 A 0 1 7 3 2

- 17 A simplified diagram of a cyclotron is shown. In the cyclotron, protons gain energy. Protons are produced in the source and initially travel in the direction shown.

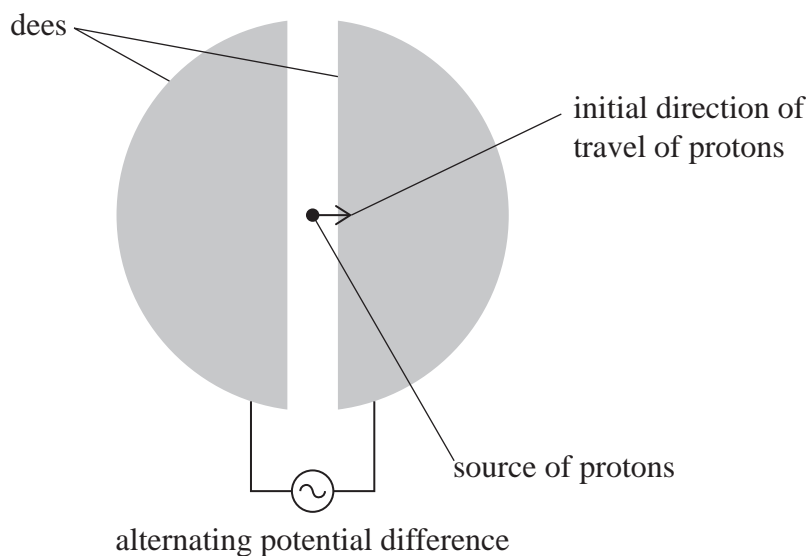

A magnetic field is applied perpendicular to the dees. The magnetic field direction is into the page.

- (a) Add to the diagram to show the path of the protons as they gain energy in the cyclotron. (2)
- (b) The frequency  $f$  of the alternating potential difference applied to the dees is given by the equation

$$f = \frac{Bq}{2m}$$

where

$m$  is the mass of the proton

$B$  is the magnetic flux density

$q$  is the charge on the proton.

Calculate the time a proton spends in one of the dees.

$B = 0.55\text{T}$

(3)

.....

.....

.....

.....

.....

Time = .....



DO NOT WRITE IN THIS AREA

DO NOT WRITE IN THIS AREA

DO NOT WRITE IN THIS AREA



18 The diagram shows a key card and a card reader used to unlock a door. To unlock the door the key card is moved downwards through the card reader.

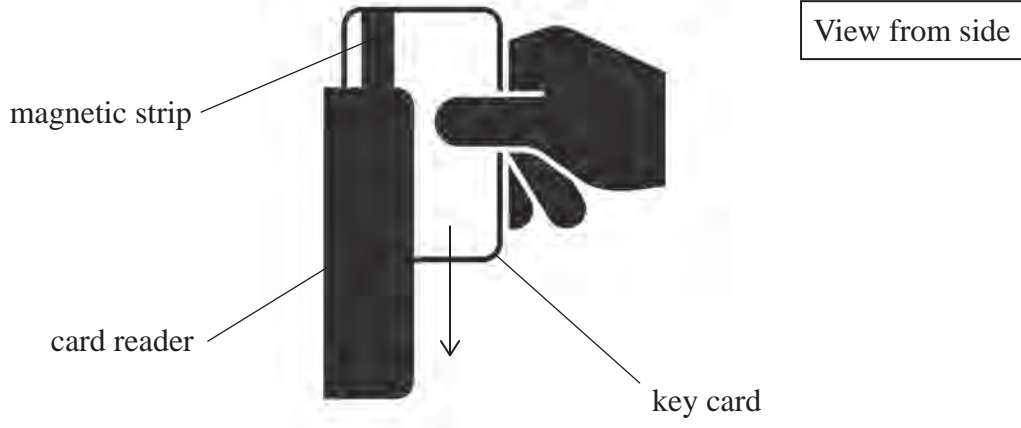

(Source: © Janis Abolins/Shutterstock)

The key card contains a magnetic strip consisting of many tiny bar magnets arranged side by side. The orientation of the magnetic poles of the bar magnets stores the code to unlock the door.

In the card reader there is a coil connected to a voltage sensor, as shown below.

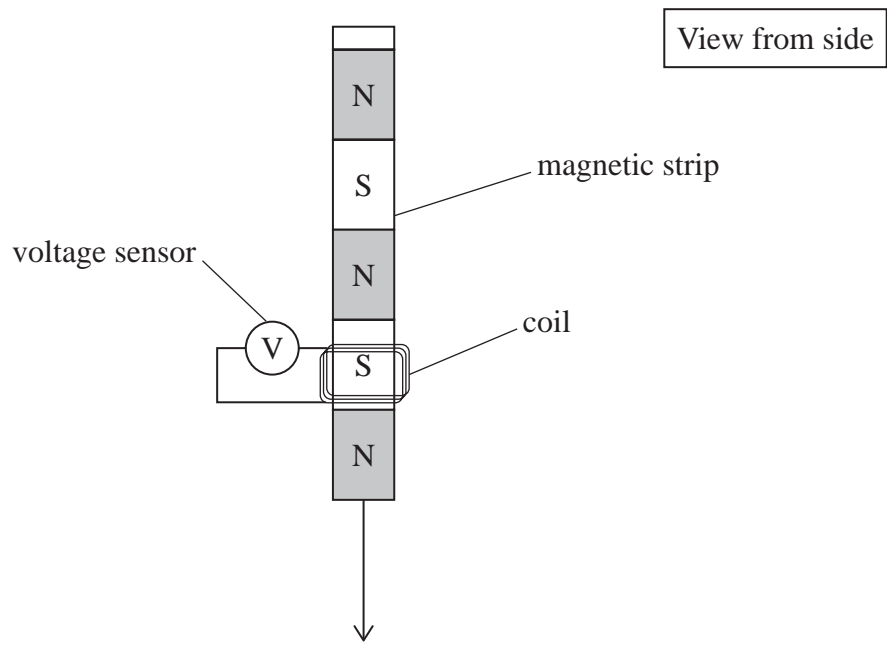

DO NOT WRITE IN THIS AREA

DO NOT WRITE IN THIS AREA

DO NOT WRITE IN THIS AREA



(a) Explain how the voltage sensor detects the orientation of the magnetic poles.

(4)

(b) The card reader can determine the orientation of a magnetic pole if the reading on the voltage sensor is greater than  $1.5 \times 10^{-6}$  V.

The key card is moved down a distance of 9.0 cm through the card reader in a time of 0.032 s.

Deduce whether the card reader can determine the orientation of the magnetic pole.

number of turns on coil = 25

magnetic flux density due to each magnet =  $2.4 \times 10^{-5}$  T

width of each magnet = 0.98 mm

(5)

(Total for Question 18 = 9 marks)



P 7 8 4 7 8 A 0 2 1 3 2

- 19 The photograph shows a theme park attraction. Small electric cars are driven on a horizontal surface. The cars sometimes collide.



electric car

rubber strip

(Source: © Albin Raj Clicks/Alamy Stock Photo)

- (a) There is a thick rubber strip around the base of each car. Two cars collide and come to rest.

Explain why the rubber strip reduces the likelihood of injury to the drivers.

You should refer to change in momentum.

(3)

.....

.....

.....

.....

.....

.....

DO NOT WRITE IN THIS AREA

DO NOT WRITE IN THIS AREA

DO NOT WRITE IN THIS AREA





- 20 A student connected the circuit shown to investigate the charging and discharging of a capacitor.

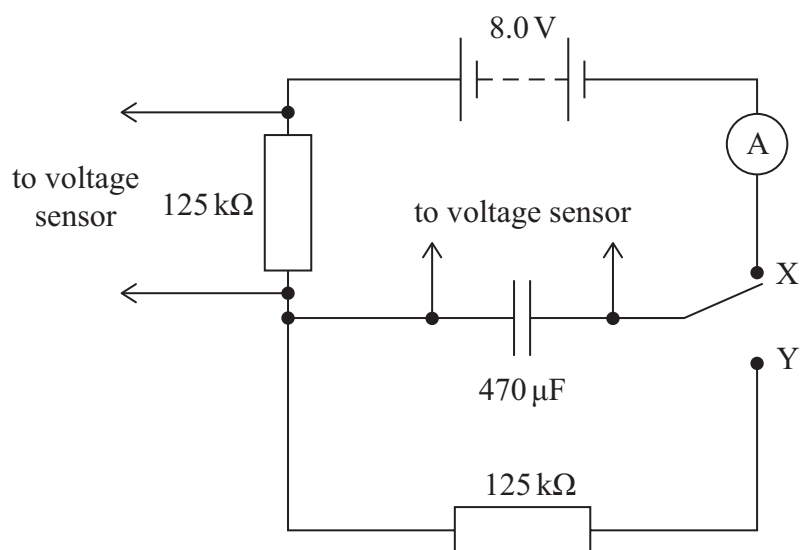

- (a) She connected the switch to position X to charge the capacitor.
- (i) Explain how the current in the circuit varies when the switch is connected to position X.

You do not need to do any calculations.

(4)

DO NOT WRITE IN THIS AREA

DO NOT WRITE IN THIS AREA

DO NOT WRITE IN THIS AREA



- (ii) Sketch a graph to show the variation of current in the circuit as the capacitor is charged.

Include the maximum value of current in the circuit.

(3)



- (b) To discharge the capacitor, the student connected the switch to position Y.

- (i) Show that the time constant of the circuit is about 60 s.

(2)

- (ii) The student connected the switch to position Y for a time of 3 minutes.

Determine, using the time constant of the circuit, the percentage of the original potential difference (p.d.) remaining across the capacitor.

(3)

Percentage of original p.d. remaining across capacitor = .....



P 7 8 4 7 8 A 0 2 5 3 2

(c) After the capacitor was fully discharged, the student connected the switch back to position X to recharge the capacitor. The student used the voltage sensors to measure the p.d.  $V_C$  across the capacitor and the p.d.  $V_R$  across the resistor. Both sensors were attached to a data logger.

The output from the data logger is shown below.

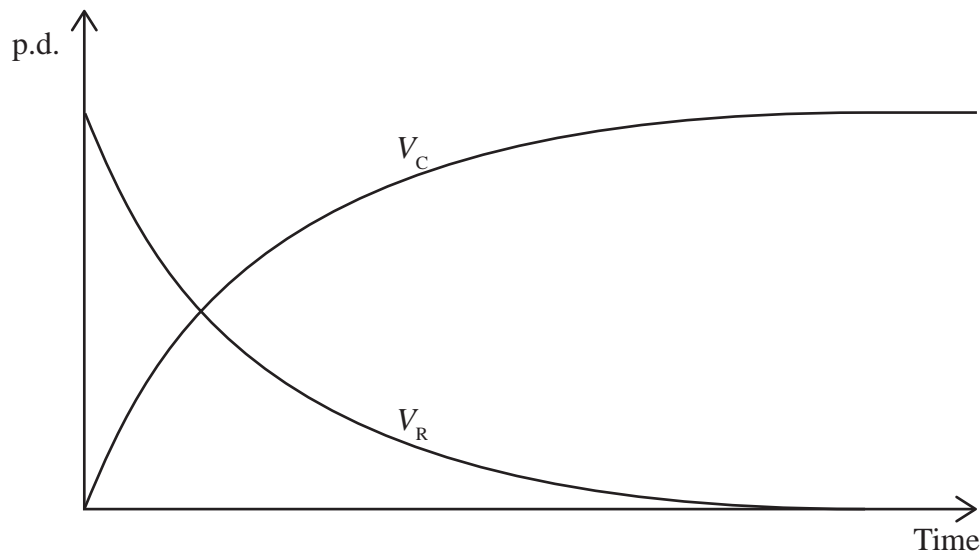

Determine the value of the p.d. and the value of the time where the two lines intersect.

(4)

.....

.....

.....

.....

.....

.....

.....

.....

.....

p.d. = .....

Time = .....



- (d) The student connected a second identical capacitor in series with the first capacitor. She connected the switch to position X to charge both capacitors.

Explain how the magnitude of charge stored on each capacitor compares with the charge that was stored on the single capacitor.

You do not need to do any further calculations.

(2)

---

(Total for Question 20 = 18 marks)

---

**TOTAL FOR SECTION B = 80 MARKS**  
**TOTAL FOR PAPER = 90 MARKS**

DO NOT WRITE IN THIS AREA

DO NOT WRITE IN THIS AREA

DO NOT WRITE IN THIS AREA



### List of data, formulae and relationships

Acceleration of free fall	$g = 9.81 \text{ m s}^{-2}$	(close to Earth's surface)
Boltzmann constant	$k = 1.38 \times 10^{-23} \text{ J K}^{-1}$	
Coulomb's law constant	$k = 1/4\pi\epsilon_0$ $= 8.99 \times 10^9 \text{ N m}^2 \text{ C}^{-2}$	
Electron charge	$e = -1.60 \times 10^{-19} \text{ C}$	
Electron mass	$m_e = 9.11 \times 10^{-31} \text{ kg}$	
Electronvolt	$1 \text{ eV} = 1.60 \times 10^{-19} \text{ J}$	
Gravitational constant	$G = 6.67 \times 10^{-11} \text{ N m}^2 \text{ kg}^{-2}$	
Gravitational field strength	$g = 9.81 \text{ N kg}^{-1}$	(close to Earth's surface)
Permittivity of free space	$\epsilon_0 = 8.85 \times 10^{-12} \text{ F m}^{-1}$	
Planck constant	$h = 6.63 \times 10^{-34} \text{ J s}$	
Proton mass	$m_p = 1.67 \times 10^{-27} \text{ kg}$	
Speed of light in a vacuum	$c = 3.00 \times 10^8 \text{ m s}^{-1}$	
Stefan-Boltzmann constant	$\sigma = 5.67 \times 10^{-8} \text{ W m}^{-2} \text{ K}^{-4}$	
Unified atomic mass unit	$u = 1.66 \times 10^{-27} \text{ kg}$	

### Unit 1

#### Mechanics

Kinematic equations of motion	$s = \frac{(u + v)t}{2}$
	$v = u + at$
	$s = ut + \frac{1}{2}at^2$
	$v^2 = u^2 + 2as$

Forces	$\Sigma F = ma$
	$g = \frac{F}{m}$
	$W = mg$

Momentum	$p = mv$
----------	----------

Moment of force	moment = $Fx$
-----------------	---------------

Work and energy	$\Delta W = F\Delta s$
	$E_k = \frac{1}{2}mv^2$

	$\Delta E_{\text{grav}} = mg\Delta h$
--	---------------------------------------

Power	$P = \frac{E}{t}$
	$P = \frac{W}{t}$

DO NOT WRITE IN THIS AREA

DO NOT WRITE IN THIS AREA

DO NOT WRITE IN THIS AREA



Efficiency

$$\text{efficiency} = \frac{\text{useful energy output}}{\text{total energy input}}$$

$$\text{efficiency} = \frac{\text{useful power output}}{\text{total power input}}$$

*Materials*

Density

$$\rho = \frac{m}{V}$$

Stokes' law

$$F = 6\pi\eta rv$$

Hooke's law

$$\Delta F = k\Delta x$$

Elastic strain energy

$$\Delta E_{\text{el}} = \frac{1}{2}F\Delta x$$

Young modulus

$$E = \frac{\sigma}{\varepsilon} \text{ where}$$

$$\text{Stress } \sigma = \frac{F}{A}$$

$$\text{Strain } \varepsilon = \frac{\Delta x}{x}$$

DO NOT WRITE IN THIS AREA

DO NOT WRITE IN THIS AREA

DO NOT WRITE IN THIS AREA



P 7 8 4 7 8 A 0 2 9 3 2

**Unit 2****Waves**

Wave speed	$v = f\lambda$
Speed of a transverse wave on a string	$v = \sqrt{\frac{T}{\mu}}$
Intensity of radiation	$I = \frac{P}{A}$
Refractive index	$n_1 \sin \theta_1 = n_2 \sin \theta_2$ $n = \frac{c}{v}$
Critical angle	$\sin C = \frac{1}{n}$
Diffraction grating	$n\lambda = d \sin \theta$

**Electricity**

Potential difference	$V = \frac{W}{Q}$
Resistance	$R = \frac{V}{I}$
Electrical power, energy	$P = VI$ $P = I^2R$ $P = \frac{V^2}{R}$ $W = VIt$
Resistivity	$R = \frac{\rho l}{A}$
Current	$I = \frac{\Delta Q}{\Delta t}$ $I = nqvA$
Resistors in series	$R = R_1 + R_2 + R_3$
Resistors in parallel	$\frac{1}{R} = \frac{1}{R_1} + \frac{1}{R_2} + \frac{1}{R_3}$

**Particle nature of light**

Photon model	$E = hf$
Einstein's photoelectric equation	$hf = \phi + \frac{1}{2}mv_{\max}^2$
de Broglie wavelength	$\lambda = \frac{h}{p}$

DO NOT WRITE IN THIS AREA

DO NOT WRITE IN THIS AREA

DO NOT WRITE IN THIS AREA



**Unit 4***Further mechanics*

Impulse

$$F\Delta t = \Delta p$$

Kinetic energy of a non-relativistic particle

$$E_k = \frac{p^2}{2m}$$

Motion in a circle

$$v = \omega r$$

$$T = \frac{2\pi}{\omega}$$

$$a = \frac{v^2}{r}$$

$$a = r\omega^2$$

Centripetal force

$$F = ma = \frac{mv^2}{r}$$

$$F = mr\omega^2$$

*Electric and magnetic fields*

Electric field

$$E = \frac{F}{Q}$$

Coulomb's law

$$F = \frac{Q_1 Q_2}{4\pi\epsilon_0 r^2}$$

$$E = \frac{Q}{4\pi\epsilon_0 r^2}$$

$$E = \frac{V}{d}$$

Electrical potential

$$V = \frac{Q}{4\pi\epsilon_0 r}$$

Capacitance

$$C = \frac{Q}{V}$$

Energy stored in capacitor

$$W = \frac{1}{2}QV$$

$$W = \frac{1}{2}CV^2$$

$$W = \frac{1}{2}\frac{Q^2}{C}$$

Capacitor discharge

$$Q = Q_0 e^{-t/RC}$$

DO NOT WRITE IN THIS AREA

DO NOT WRITE IN THIS AREA

DO NOT WRITE IN THIS AREA



P 7 8 4 7 8 A 0 3 1 3 2

Resistor-capacitor discharge

$$I = I_0 e^{-t/RC}$$

$$V = V_0 e^{-t/RC}$$

$$\ln Q = \ln Q_0 - \frac{t}{RC}$$

$$\ln I = \ln I_0 - \frac{t}{RC}$$

$$\ln V = \ln V_0 - \frac{t}{RC}$$

In a magnetic field

$$F = Bqv \sin \theta$$

$$F = BIl \sin \theta$$

Faraday's and Lenz's laws

$$\mathcal{E} = \frac{-d(N\phi)}{dt}$$

*Nuclear and particle physics*

In a magnetic field

$$r = \frac{p}{BQ}$$

Mass-energy

$$\Delta E = c^2 \Delta m$$

DO NOT WRITE IN THIS AREA

DO NOT WRITE IN THIS AREA

DO NOT WRITE IN THIS AREA

